

**Thank you for choosing NIVELCO instrument**  
**We are convinced that you will be satisfied with our product!**

# NIPRESS

D□□-9□□-□  
 PRESSURE TRANSMITTER

User's Manual



Manufacturer:  
 NIVELCO Process Control Co.  
 H-1043 Budapest, Dugonics u. 11.  
 Tel.: (36-1) 889-0100 Fax: 889-0200  
 E-mail: sales@nivelco.com www.nivelco.com



NIVELCO

## 1. APPLICATION

The **NIPRESS D-900** series with ceramic internal sensor measure pressure and convert it into voltage and current output can be used in either 2- and 3-wire systems. D-900 was especially designed for low system, pressure measurement applications in plant and machine engineering, biogas plants, as well as laboratory techniques. The pressure transmitter is suitable for measuring small system pressure, however due to its optional Al<sub>2</sub>O<sub>3</sub> 99.9% sensor it also offers high temperature, overpressure, and media resistance. Its modular construction provides high flexibility to the user. Transmitters can be delivered with plug in display **UNICONT PLK-501** enabling on site reading. Ex versions are also available.

## 2. TECHNICAL DATA

### GENERAL DATA

| TYPE   |                | D□□-9□□-2, -6  | DRD - 9□2 - 3            |
|--|----------------|--|--------------------------|
| Measurement range                                  |                | 0 - 20 bar (0 - 290 psig)<br>(according to the order code)   |                          |
| Overload capability                                |                | According to the order code  |                          |
| Accuracy   |                | p <sub>N</sub> ≥ 0.6 bar: 0.25%;<br>0.5 %  |                          |
| Medium temperature                                 |                | -40 °C ... +125 °C (-40 °F ... +257 °F)  |                          |
| Ambient temperature <sup>(1)</sup>                 |                | -25 °C ... +85 °C (-13 °F ... +185 °F)<br>(with integrated cable: -5 °C ... +70 °C [+23 °F ... +158 °F])       |                          |
| Materials of the wetted parts                      | Sensor         | Aluminium oxide ceramic Al <sub>2</sub> O <sub>3</sub> 96 %<br>Optional: Al <sub>2</sub> O <sub>3</sub> 99.9 % |                          |
|  | Sensor sealing | FKM (Viton®)<br>Optional: EPDM   |                          |
|  | Process conn.  | Stainless steel 1.4404 (316L)  |                          |
| Housing  |                | Stainless steel 1.4404 (316L)<br>Optional: Stainless steel 1.4305 (304)  |                          |
| Output   |                | 2-wire 4 - 20 mA   | 3-wire 0 - 10 V          |
| Power supply (U <sub>supply</sub> ) <sup>(1)</sup> |                | standard version: 9 - 32 V DC  | 12.5 - 32 V DC           |
| Load resistance                                    |                | R <sub>max</sub> = [(U <sub>supply</sub> - U <sub>supply min.</sub> ) / 0.02 A], [Ω]                           | R <sub>min</sub> = 10 kΩ |
| Process connection                                 |                | According to the order code  |                          |
| Electrical connection                              |                | ISO 4400, M12x1 (4-pin), integrated cable  |                          |
| Ingress protection                                 |                | IP65 (ISO 4400), IP67 (M12x1), IP68 (integrated cable with ventilation tube)                                   |                          |
| Electric protection                                |                | Class III (SELV)   |                          |
| Mass   |                | ~0.2 kg (~0.44 lb)   |                          |

<sup>(1)</sup> For information of Ex certified devices (D□□ - 9□□ - 6 Ex), see Special data for Ex certified models' chart

### 2.1 ACCESSORIES

- User's manual
- Warranty Card
- EU Declaration of Conformity

### SPECIAL DATA FOR EX CERTIFIED MODELS (ONLY FOR 4 - 20 mA / 2-WIRE)

| Type   | D□□ - 9□□ - 6 Ex  |
|--|---|
| Ex marking   | (Pending.)  |
| Ex reference document number   | (Pending.)  |
| Ex power supply  | 10 - 28 V DC  |
| Intrinsically safety data  | U <sub>imax</sub> = 28 V DC, I <sub>imax</sub> = 93 mA, P <sub>imax</sub> = 660 mW, C <sub>i</sub> ≈ 27 nF, L <sub>i</sub> ≈ 5 μH |
|  | The maximum interior capacity between the power supply connections and the metal housing is 27 nF.                                |
| Permissible medium temperature, atmospheric pressure                       | Zone 0: -20 °C ... +60 °C (-4 °F ... +140 °F), 0.8 bar ≤ p <sub>atm</sub> ≤ 1.1 bar   |
|  | Zone 1, 2: -20 °C ... +70 °C (-4 °F ... +158 °F)<br>For T6 application: -25 °C ... 60 °C (-13 °F ... +140 °F)                     |
| Connecting cable (in case if the device equipped with an integrated cable) | Cable capacitance: 160 pF/m<br>Cable inductivity: 1 μH/m  |

### 2.2 ORDER CODE (NOT ALL COMBINATIONS POSSIBLE!)

**NIPRESS**      D □ □ - 9 □ □ - □

| MEASURING METHOD                  | CODE | PROCESS CONNECTION | CODE | RANGE <sup>(1)</sup> / NOMINAL PRESSURE (bar) | CODE | ACCURACY                         | CODE | OUTPUT / Ex                              | CODE |
|-----------------------------------|------|--------------------|------|---|------|----------------------------------|------|--|------|
| Gauge                             | R    | ¼" BSP             | A    | 0 - 0.04 / 2                                  | O    | 0.25% (p <sub>N</sub> ≥ 0.6 bar) | 1    | 4 - 20 mA, 2-wire                        | 2    |
| Absolute (p <sub>N</sub> ≥ 1 bar) | E    | ½" BSP             | C    | 0 - 0.06 / 2                                  | P    | 0.5%                             | 2    | 0 - 10 V, 3-wire                         | 3    |
|                                   |      | ½" NPT             | H    | 0 - 0.1 / 4                                   | 1    |                                  |      | 4 - 20 mA, 2-wire / Ex ia <sup>(2)</sup> | 6    |
|                                   |      | M20x1.5            | J    | 0 - 0.16 / 4                                  | R    |                                  |      |  |      |
|                                   |      |                    |      | 0 - 0.25 / 6                                  | 2    |                                  |      |  |      |
|                                   |      |                    |      | 0 - 0.4 / 6                                   | 3    |                                  |      |  |      |
|                                   |      |                    |      | 0 - 0.6 / 8                                   | 4    |                                  |      |  |      |
|                                   |      |                    |      | 0 - 1 / 8                                     | 5    |                                  |      |  |      |
|                                   |      |                    |      | 0 - 1.6 / 15                                  | 6    |                                  |      |  |      |
|                                   |      |                    |      | 0 - 2.5 / 25                                  | 7    |                                  |      |  |      |
|                                   |      |                    |      | 0 - 4 / 25                                    | 8    |                                  |      |  |      |
|                                   |      |                    |      | 0 - 6 / 35                                    | 9    |                                  |      |  |      |
|                                   |      |                    |      | 0 - 10 / 35                                   | A    |                                  |      |  |      |
|                                   |      |                    |      | 0 - 16 / 45                                   | B    |                                  |      |  |      |
|                                   |      |                    |      | 0 - 20 / 45                                   | T    |                                  |      |  |      |

<sup>(1)</sup> Custom measuring range, based on prior negotiations

<sup>(2)</sup> Ex versions are available upon special request

**Note:**

In case of non-standard applications, the sensor type, sealing and housing, as well as the requirement for filling with food compatible oil has to be specified in the order!

## 2.3 DIMENSIONS

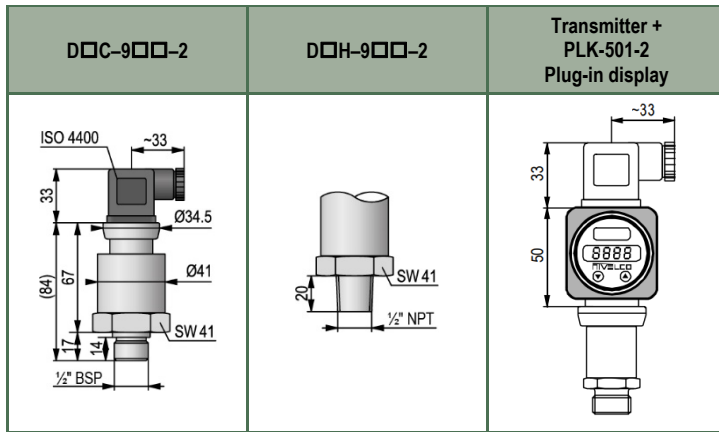

## 3. INSTALLATION

Due to its small size and weight the transmitter can be directly installed on tanks, pipes, machines, etc. without any mounting aids.

To enable the safe replacement of the instrument during operation the use of closing armature is recommended. A simple ball valve will be suitable for lower pressures and for higher pressures (above 6 bar) a three-way blow-off needle-valve can be suggested.

In case of outside installation, the unit should be protected against rain or splash water, because malfunction may occur from a leakage if the connector's screw is improperly tightened (i.e. not appropriate sealing).

### 3.1 INSTALLATION INSTRUCTION

The measured medium – depending on its type and properties, might be hazardous to the installer. Therefore, the wear of appropriate protective clothing, gloves, and goggles are recommended.

Be careful because the membrane is very vulnerable!

Torque should only be transferred to the hexagonal screw on the instrument body (torque wrench). **The cylindrical housing of the transmitter must not be gripped and tightened with a pipe wrench!**

The plug-in electric connector can be unplugged after releasing and removing its fastening screw. The connection insert can be pushed out by a screw driver from the direction of the screw. The terminal block can be rotated with 90° within the housing, so that the orientation of the cable gland could be changed to face downwards. This is to prevent any leakages of the housing and subsequent damages may occur. The power cable is to be connected with the relevant points of the connector by guiding it through the cable gland (ISO 4400). Make sure if the cable gland and the sealing plate of the connector tightened properly! Tighten the screw of the connector so that the sealing plate underneath seals properly!

For the sake of noise suppression, the transmitter housing is grounded. If the grounding of the process is correct no further grounding is needed, otherwise the instrument should be grounded.

When installing the device, avoid high mechanical stresses on the pressure port! This is particularly true for the pressure port made of plastic.

#### Installation steps:

Tightening torques:

1/4" BSP: max. 5 Nm;

1/2" BSP: max. 10 Nm;

1/4" NPT: max. 30 Nm;

**The specified tightening torques must not be exceeded!**

#### Mounting steps for BSP thread connections according to DIN 3852:

Do not use any additional sealing material such as Teflon tape! Check if the O-ring is undamaged, it has a flawless and clean surface and seats in the designated groove properly. Screw the device into the corresponding thread by hand, and tighten the parts with a suitable torque wrench.

#### Mounting steps for NPT thread connections:

Use a suitable sealant (e.g. PTFE tape). Turn the device by hand to the correct thread and tighten it with an open-end torque wrench.

If your device can be secured with a knurled ring, the pressure transmitter should only be tightened by hand!

## 4. WIRING

Use a shielded and twisted multicore cable for the electrical connection. Electrically connect the device according to the "Connection of ISO 4400 plug" figure. For devices with cable gland, make sure that the external diameter of the cable used is within the allowed clamping range! Once connected the wires, tighten the gland screw firmly until the sealing is proper!

For the installation of a device with an integrated cable, the bending radiuses have to comply with the following:

Cable without ventilation tube:

- static installation: 8-fold cable diameter,
- dynamic application: 12-fold cable diameter.

Cable with ventilation tube:

- static installation: 10-fold cable diameter,
- dynamic application: 20-fold cable diameter.

In case of devices with cable outlet and integrated ventilation tube, the PTFE filter located at the cable end on the ventilation tube must not be damaged or missing!

### 2-wire current output

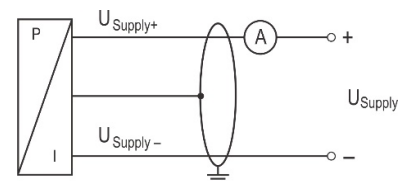

### 3-wire voltage output

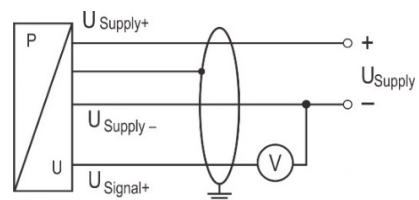

### Connection of integrated cable



### Connection of iso 4400 plug

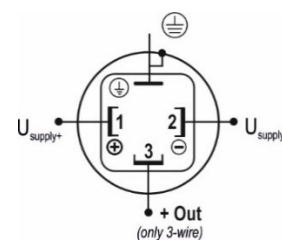

### Connection of M12x1 / 4 pin plug

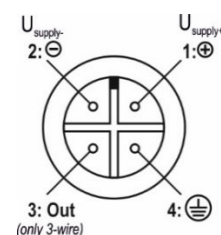

## 4.1 EXAMPLES OF ARRANGEMENTS

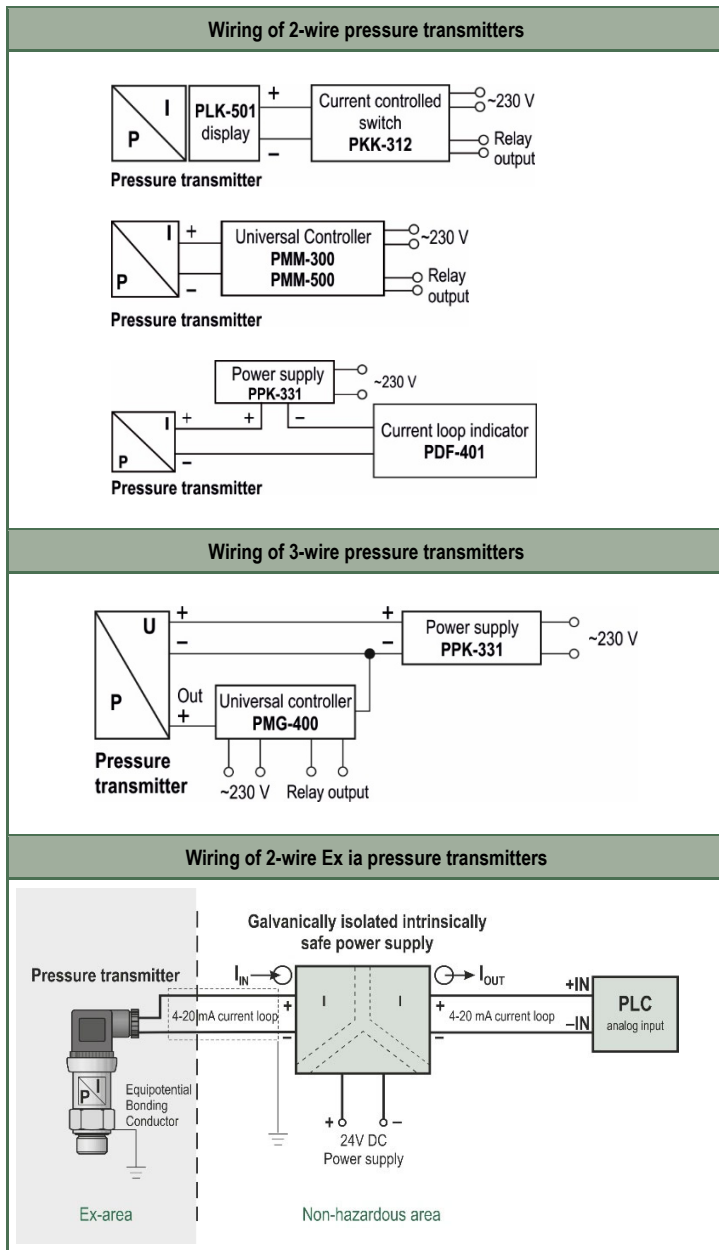

## 5. SPECIAL CONDITIONS OF SAFE USE



- Before turning on the device, make sure the installation is complete, with no effects visible.
- The device may only be used within the limitations specified in the technical specifications.
- The electrical connection of the device must be carried out in a way that the IP20 ingress protection is always ensured.
- Ex ia certified transmitters may only be operated in certified and approved galvanically isolated intrinsically safe Ex ia circuits complying with the technical data and the device's explosion protection marking!
- The metal housing of the device must be connected to the EP (equipotential) network!
- **Attention!** The devices may partially contain static charging capable plastic components. The presence of electrostatic charges may cause a risk of spark generation and ignition and therefore electrostatic charges must be completely prevented!
  - Avoid friction on plastic surfaces!
  - Do not clean the device dry!
  - For example, use a wet duster.

## 6. TROUBLESHOOTING

| Fault                                | Possible causes  | Fault detection / remedy  |
|--------------------------------------|--|---|
| No output signal:                    | Connected incorrectly.   | Check the connections!  |
|                                      | Conductor/wire breakage.   | Check all wires with cable tester!  |
|                                      | Defective measuring device (signal input).                                       | Check the amperemeter (and its fuse) and the analogue input of the signal processing unit!    |
| Analog output signal too low:        | Load resistance too high.  | Check the value of the load resistance!   |
|                                      | Supply voltage too low.  | Check the power supply and power /current on the transducer/transmitter!                      |
| A slight shift of the output signal: | The diaphragm of the sensor is severely contaminated.                            | Cleaning with non-aggressive cleaning solutions, soft brush or sponge.                        |
|                                      | The diaphragm of the sensor is calcified or crusted.                             | It is recommended to clean carefully and remove dirt.   |
| A large shift of the output signal:  | The diaphragm of the sensor is damaged (caused by overpressure or mechanically). | Check the diaphragm of the sensor, if it is damaged send the device back to the manufacturer! |

## 7. MAINTENANCE AND REPAIR

The instrument does not require regular maintenance. The repair should only be carried out at NIVELCO's premises.

When disconnecting the device, it must always be done in depressurized and disconnected state! Drain the medium before disconnecting the device. If necessary, clean the diaphragm carefully with non-aggressive cleaning solution, soft paint-brush or sponge. Improper cleaning may cause the irreparable damage of the diaphragm. For this reason, never use sharp objects or pressurized air for cleaning the diaphragm.

Before returning your device for repair, it has to be cleaned carefully, neutralize/decontaminate the parts wet from the medium might contain harmful substances.

Our official form (Returned Equipment Handling Form) must be enclosed after downloaded from our homepage [www.nivelco.com](http://www.nivelco.com). You should dispatch the device with a declaration of decontamination. In the declaration, you have to provide a statement that the decontamination process is completed, and the device is clean and free from harmful material and there is no hazardous substance on it.

## 8. STORAGE CONDITIONS

Storage temperature: -40 °C ... +100 °C (-40 °F ... +212 °F)

drc9122a0600h\_01  
July 2020.

NIVELCO reserves the right to change technical data without notice!